

EKSON

**PRODUCT
CATALOGUE
2019**





Ekson is an automation company specialized on system and equipment design&development for the industry applications with innovative and sustainable solutions, especially for the wire harness producers.

In our portfolio ,we have standard machines and also have tailor made solutions for e-mobility processes. Many of our machines working in increasing number of electrical/hybrid car harness manufacturing processes



EKSON is covering three continents longest 3 hours flight



HV Cable Processing Devices



EX-M-BC01 Shield Cutting Machine

(up to 95 mm²)

Eliminates different machines usage for different cutting lengths

Parametric machine software

Dimensions	821x400x540 mm
Input Voltage	220V AC
Frequency	50 Hz
Electrical Power	1.7 kW
Weight	65 Kg
Cutting Length	3mm to 100mm
Applicable Cable Size	Outer Diameter: \varnothing 6-22 mm
Applicable Cable Type	HV Cables and Other Shielded Cables



EX-VA-02 Vacuum Device

(up to 21 ø)

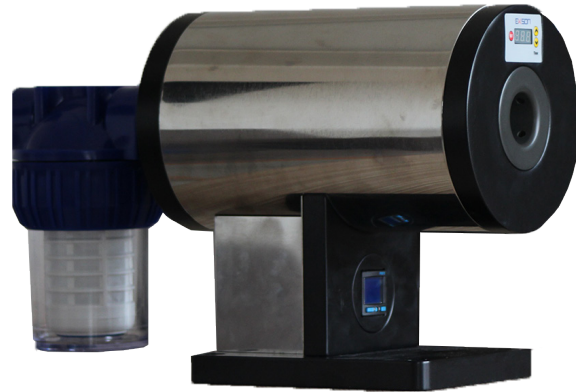

Compact and powerful
Easy to clean filter system

Dimensions	460x155x267 mm
Input Voltage	12VDC/2A
Adaptor Feature	In:110-220VAC 50/60Hz out: 12VDC/2A
Electrical Power	24W
Weight	9 Kg
Applicable Cable Size to Clean	Max.Outer diameter: 20mm
Applicable Cable Length to Clean	Max. 300mm
Applicable Cable Type	HV Cables and Other Shielded Cables



EX-M3-IR HV Cable Braid Brushing Machine

Unique brushes and unique adjustment system
No need to turn your cable to brush

Dimensions	400x385x205 mm
Input Voltage	220V AC
Frequency	50/60 Hz
Electrical Power	120 W
Weight	13 Kg
Brushing Speed	235 RPM
Applicable Cable Size to Brush	Outer Diameter: \varnothing 1-22 mm
Applicable Cable Length to Brush	Up to 100 mm
Applicable Cable type	HV Cables and Other Shielded Cables



**HV CABLE
PROCESS TECHNOLOGY?
LET WE EXPLAIN**



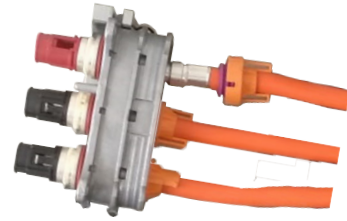
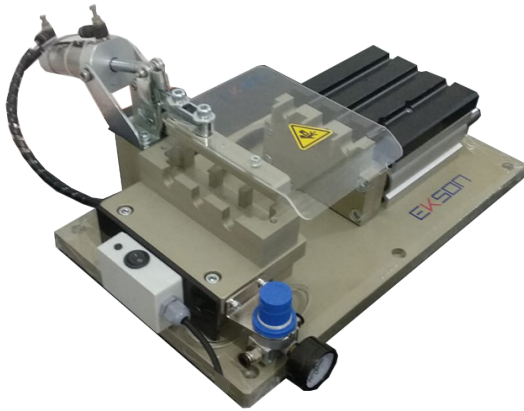

**EX-HVP-01REF06
HV Cable
Cover Assembly Device**

Dimensions	mm
Input Voltage	12VDC/2A
Adaptor Feature	In:110-220VAC 50/60Hz out: 12VDC/2A
Electrical Power	24W
Weight	



**EX-HVP-01-REF09
HV Cable
Cover Assembly Device**

Dimensions	mm
Input Voltage	12VDC/2A
Adaptor Feature	In:110-220VAC 50/60Hz out: 12VDC/2A
Electrical Power	24W
Weight	

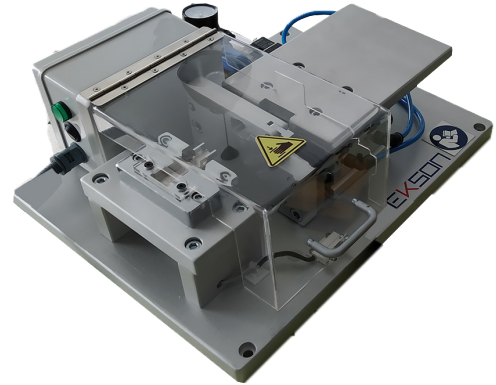

EX-CA-KS HV Cable Connector Assembly Device

Dimensions	420x350x170 mm
Input Voltage	12VDC/2A
Adaptor Feature	In:110-220VAC 50/60Hz out: 12VDC/2A
Electrical Power	24W
Weight	17.5 Kg

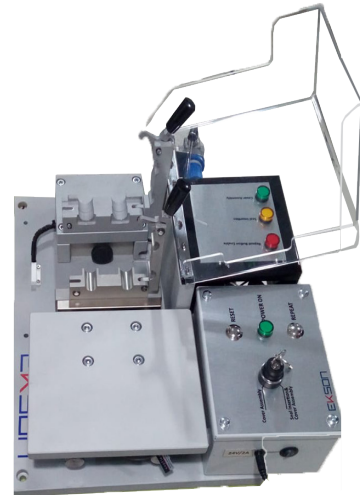

EX-CA-SP02 HV Cable Insertion Tool

Dimensions	495x440x160 mm
Input Voltage	24VDC/2A
Adaptor Feature	In:110-220VAC 50/60Hz out: 24VDC/2A
Electrical Power	48W
Weight	

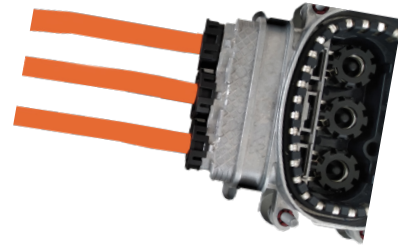
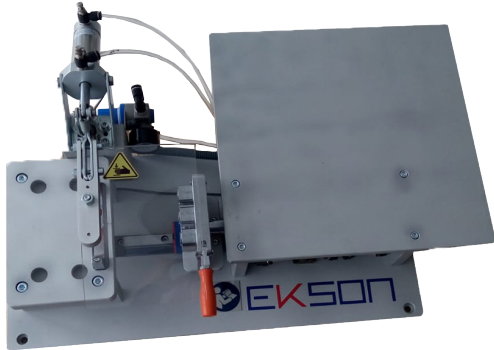

EX-HVP01 HV Cable Metal Gasket Assembly Device

Dimensions	460x440x200 mm
Input Voltage	12VDC/2A
Adaptor Feature	In:110-220VAC 50/60Hz out: 12VDC/2A
Electrical Power	24W
Weight	23.1 Kg

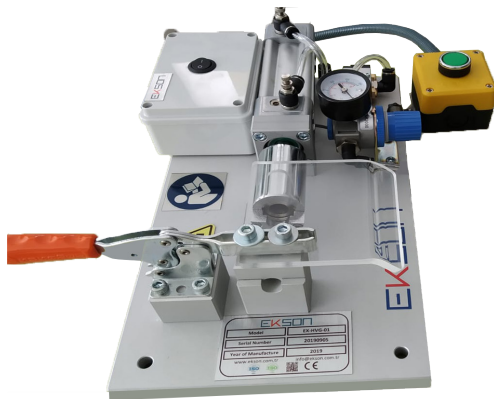

EX-HVG01 Connector Assembly Device

Dimensions	460x440x200 mm
Input Voltage	12VDC/2A
Adaptor Feature	In:110-220VAC 50/60Hz out: 12VDC/2A
Electrical Power	24W
Weight	9 Kg

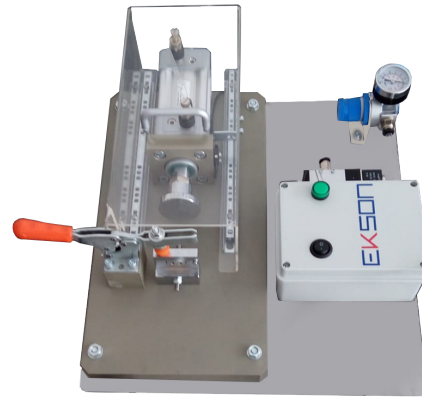

EX-CP-GT-BL HV Cable Grommet Assembly Device

Dimensions	400x400x20 mm
Input Voltage	12VDC/2A
Adaptor Feature	In:110-220VAC 50/60Hz out: 12VDC/2A
Electrical Power	24W
Weight	9 Kg

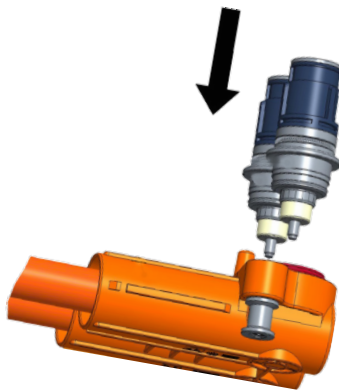

EX-CP02TP HV Cable Connector Assembly Device

Dimensions	280x490x500 mm
Input Voltage	12VDC/2A
Adaptor Feature	In:110-220VAC 50/60Hz out: 24VDC/2A
Electrical Power	24W
Weight	25 Kg

WE PREPARE ORANGE CABLES



Machining



FOR A GREEN EARTH

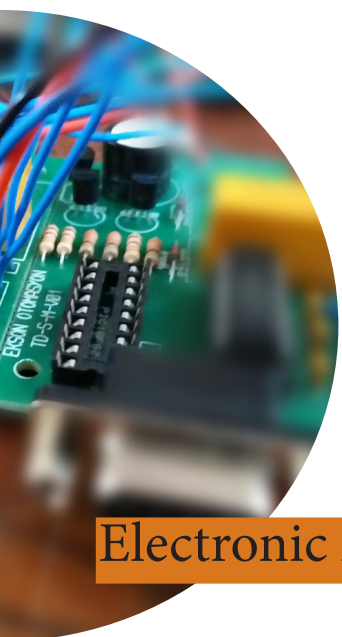

Electronic Design

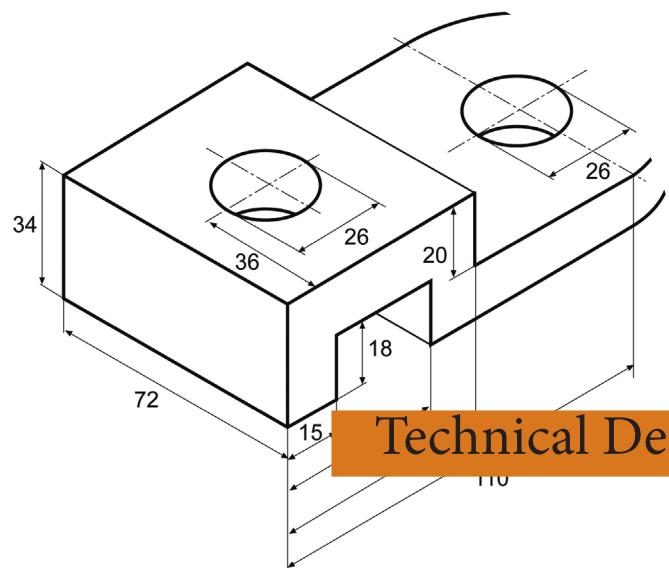

Technical Design

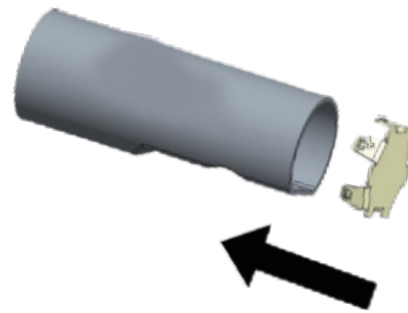

**EX-CP02C
HV Cable Connector
Cap Assembly Device**

Dimensions	320x375x225 mm
Input Voltage	12VDC/2A
Adaptor Feature	In:110-220VAC 50/60Hz out: 12VDC/2A
Electrical Power	24W
Weight	9.7 Kg

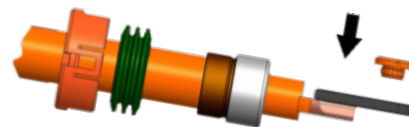

**EX-CP02R
HV Cable Assembly Press
For US Welded Terminal End**

Dimensions	305x240x225 mm
Input Voltage	12VDC/2A
Adaptor Feature	In:110-220VAC 50/60Hz out: 12VDC/2A
Electrical Power	24W
Weight	9.7 Kg



EX-CP01 HV Cable Connector Cap Assembly Device

Dimensions	317x221x229 mm
Input Voltage	12VDC/2A
Adaptor Feature	In:110-220VAC 50/60Hz out: 12VDC/2A
Electrical Power	24W
Weight	9.785 Kg

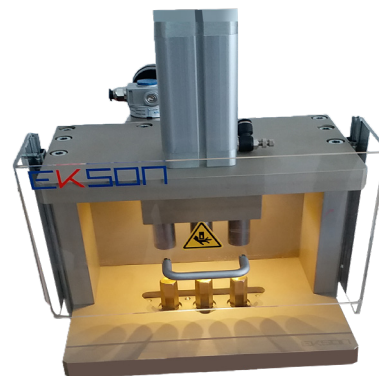

EX-CP02HX HV Cable Hexagonal Cap Assembly Press

Dimensions	320x270x270 mm
Input Voltage	12VDC/2A
Adaptor Feature	In:110-220VAC 50/60Hz out: 12VDC/2A
Electrical Power	24W
Weight	5.785 Kg

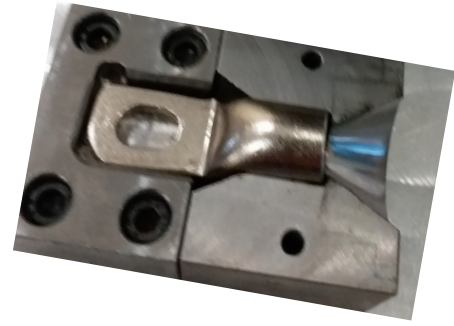

EX-CBIT HV Cable Tubular Terminal Insertial Device

Input Voltage	12VDC/2A
Adaptor Feature	In:110-220VAC 50/60Hz out: 12VDC/2A
Electrical Power	24W
Weight	3 Kg

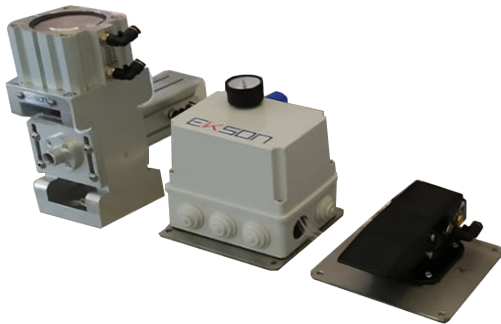

EX-M-MCC25 HV Cable Cutting Device

Dimensions	240x260x140 mm
Weight	9.9 Kg



Other Devices



EX-MWT01

Cable Twisting Machine

(20 Cables for Sliding Doors)

Unique system for a smooth gripping of the wires

Dimensions	180x150x60 cm
Input Voltage	220 VAC
Frequency	50/60 Hz
Electrical Power	740 W
Weight	180 Kg
System	Driven by servo motor

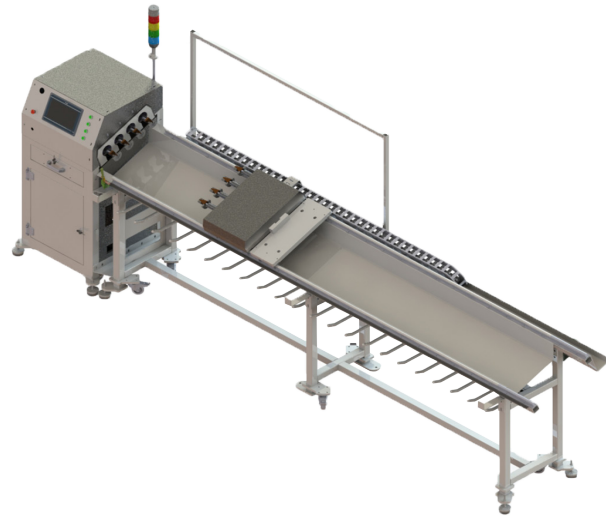

EX-WTM-19 Cable Twisting Machine (2-3 Cables)

Covers all needs of twisting process

Dimensions	4500x1900x860 mm
Input Voltage	220V
Electrical Power	1000 W
System	Driven by servo motor
HMI	10"



EX-UT01 Untwist Device

Dimensions	285x245x45 mm
Input Voltage	220 VAC
Frequency	50/60 Hz
Electrical Power	500 W
Weight	23.5 Kg



EX-HVTT Soldering Table

Dimensions	460x440x200 mm
Input Voltage	12VDC/2A
Adaptor Feature	In:110-220VAC 50/60Hz out: 12VDC/2A
Electrical Power	24W
Weight	9 Kg

Z-Cut 9GR Tape Dispenser Developed for Schunk Welding (Wired&Wireless)



Dimensions	140x140x213 mm
Input Voltage	220 V
Electrical Power	48 W
Weight	1.6 Kg

EX-SD180 Fleece Sleeve Cutting Machine

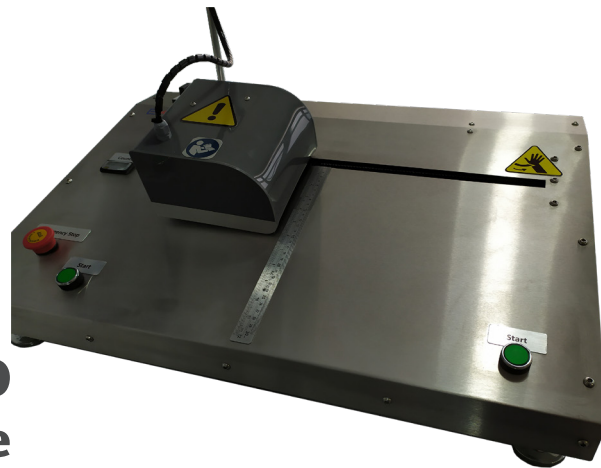

Dimensions	460x440x200 mm
Input Voltage	12VDC/2A
Adaptor Feature	In:110-220VAC 50/60Hz out: 12VDC/2A
Electrical Power	24W
Weight	23.1 Kg



EX-TSL01 Trimming and Slitting Machine

Dimensions	250x200x200 mm
Weight	17.2 Kg



Tape Dispensers Laser Dispensers



Lean Manufacturing Materials, Process Structures and Testing Equipments

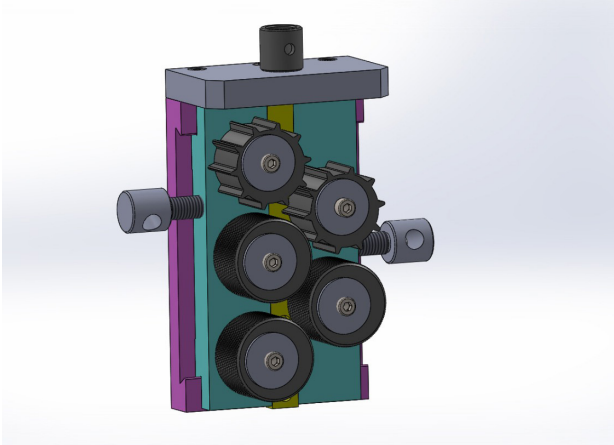
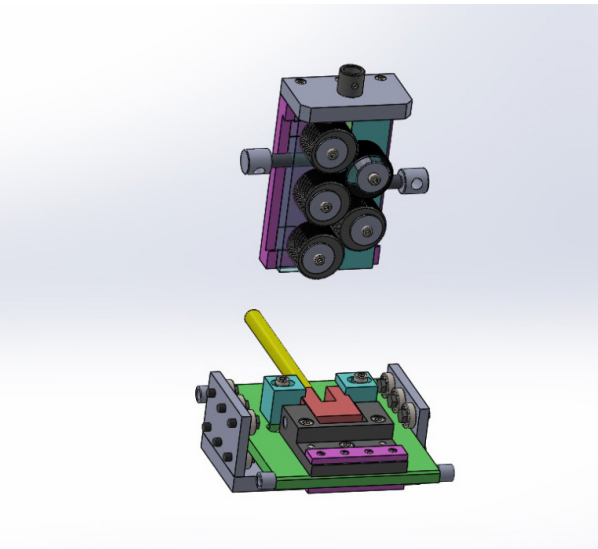

EKSON

Headquarters

Adress: Y. Dudullu Mah. Gökyüzü Sok. 19

Ümraniye/İstanbul

Tel: +90 (216) 661 41 00

Fax: +90 (216) 661 43 00

E-mail: info@ekson.com.tr

Bulgaria Office

Adress: Aytos 8500, Tsar Osvoboditel 25 parter

Bulgaria

Tel: +359 (89) 370 79 54

E-mail: bg@ekson.com.tr